



Boost Machining Efficiency and Overcome Vibration Challenges with Self-Tuning Mass Dampers (STMD™)



Revolutionizing Vibration Control in Metalworking

Vibration, both stable and unstable, is a common challenge in metalworking, leading to tool damage, surface defects, and inconsistent quality. Unstable vibration, or chatter, can cause tool

breakage, while stable vibration accelerates tool wear and reduces surface quality, ultimately increasing production costs due to higher scrap rates and damaged tools. Traditional vibration damping solutions, such as mass dampers, require manual tuning to match the tool's vibration frequency, which can be inefficient and result in downtime.

However, advanced solutions like MAQ's Self-Tuning Mass Damper (STMD™) offer a more effective approach. The STMD™ automatically adjusts to varying vibration frequencies based on tool dimensions, material, and operating conditions, eliminating the need for manual tuning. This plug-and-play technology significantly enhances machining productivity, improves tool life, and delivers superior cutting performance with minimal maintenance. Ideal for precision industries like aerospace, automotive, oil and gas, and medical component manufacturing, the STMD™ provides a cost-effective, hassle-free solution to overcome vibration-related issues and boost overall efficiency.

“The key to increasing productivity lies in controlling these vibrations.”

Machining vibrations are caused by unwanted movement between the workpiece and tool, influenced by factors such as speed, feed rate, and material properties. These vibrations can lead to surface imperfections, increased tool wear, and decreased productivity, often going unnoticed until quality issues occur. Addressing machining vibrations is essential for maintaining product quality, improving precision, and avoiding costly delays in CNC machining operations.

Solutions for Overcoming Vibration Issues in Metalworking

Standard Tool

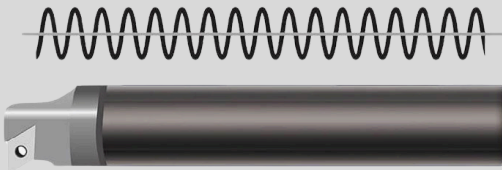

To combat these challenges, adopting vibration-dampening technologies is essential among the damping techniques used to control vibrations in machining, mass dampers on cutting tools are the most cost-effective and require the least operator engagement

Self-Tuning Mass Damper

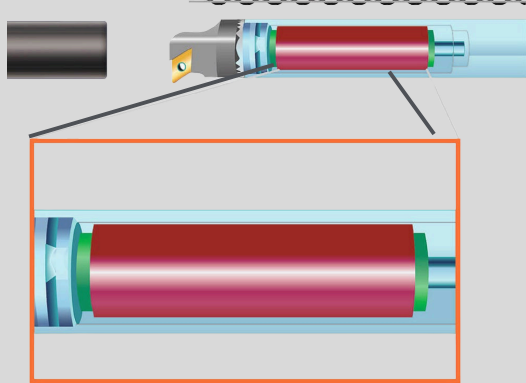

Here are some practical solutions:

1. Pre-tuned mass dampers

Mass dampers pre-tuned to specific applications (7XD, 10XD, etc.) are effective at reducing vibrations within a set frequency range. However, they work best when vibrations are predictable and consistent.

2. Self-tuning mass dampers

For operations with varying vibration frequencies, self-tuning mass dampers are ideal.

These advanced dampers automatically

adjust to multiple frequencies, providing a “plug and play” solution that simplifies the machining process. They offer longer tool life, improved surface quality, and require minimal setup.

Benefits of Vibration-Dampening Solutions

- **Increased productivity**

With better control over vibrations, production can continue at optimal speeds without compromising quality.

- **Cost savings**

Reducing tool wear and avoiding additional processes like grinding cuts operational costs.

- **Improved precision**

Vibration-dampening solutions allow for higher accuracy, reducing errors and waste.

- **Simplified setup**

Self-tuning dampers require no specialized knowledge, making them easy to implement and maintain.

How Self-Tuning Mass Dampers (STMD™) Work

MAQ's self-tuning mass damper (STMD™) technology addresses these limitations with automatic tuning that dynamically adapts to the tool's vibration frequency. The ability to adapt dynamically to different setups makes STMD™ a game-changer for applications requiring varying tool lengths and conditions.

Key Benefits of STMD™ Technology

- **Stiffness adjustment:** STMD™ use materials that adjust their stiffness based on vibration frequency. When the vibration frequency is high, the stiffness of the damper increases, and vice versa. This allows the damper to self-tune, ensuring optimal vibration control without manual adjustments.
- **Frequency range:** STMD™ covers a broad vibration frequency range, allowing it to handle tools with varying L/D (Length-to-Diameter) ratios effectively.

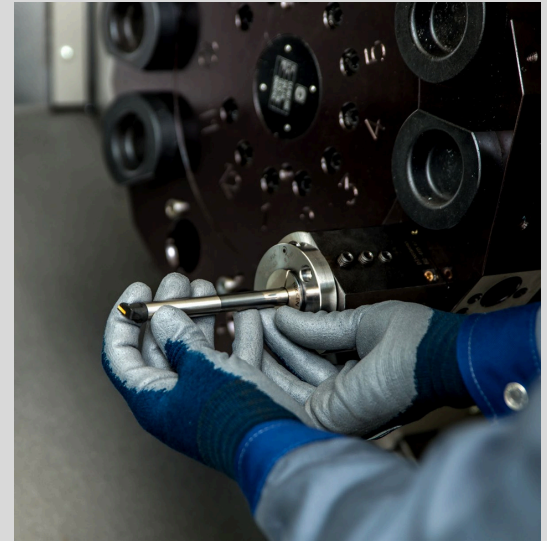

- **Vibration Amplitude:** STMD™ significantly reduces vibration amplitude when compared to traditional dampers.
- The STMD tools further **reduce the vibration amplitude** by 20 % in their sweet spot up to 50 % outside their sweet spot.
- **Plug & Play:** STMD™ offers a plug-and-play experience. Once installed, the damper automatically adjusts to the tool's vibration frequency without the need for manual tuning or recalibration.

Productivity Gains with MAQ STMD™

By eliminating the need for manual tuning, STMD™ enables substantial improvements in machining productivity:

- **Increased cutting speeds and feeds:** With STMD™ technology, machines can operate at higher speeds and feeds without risking unstable vibrations.
- **Improved surface finish:** STMD™ improves the quality of the machined surface by reducing vibration, allowing for more precise and smoother cuts.
- **Extended tool life:** Vibration leads to accelerated tool wear. By damping vibrations, STMD™ extends the life of cutting tools by reducing wear rates.

By choosing MAQ, you gain

- **Higher feed rates and better surface quality, enabling faster production cycles**
- **Reduced tooling costs and improved tool life due to reduced vibration wear**
- **Consistent performance without the need for manual tuning or maintenance**
- **Maintenance-free operation and ease of use (plug-and-play installation)**

Enhancing Metalworking Efficiency

MAQ's self-tuning mass damper (STMD™) technology offers a revolutionary solution to controlling vibration in machining, automatically adjusting to vibration frequencies to improve surface finish, extend tool life, and boost productivity. This game-changing technology enhances machining stability, making operations more efficient, predictable, and cost-effective. Whether you're a job shop owner or manufacturing engineer, adopting STMD™ can significantly reduce costs and improve performance. By integrating vibration-dampening technology, metalworking operations can achieve higher precision, better product quality, and increased efficiency. Contact us today to discover how our solutions can streamline your machining process and elevate your operations.